

1216 TRAINING WHEEL ASSEMBLY

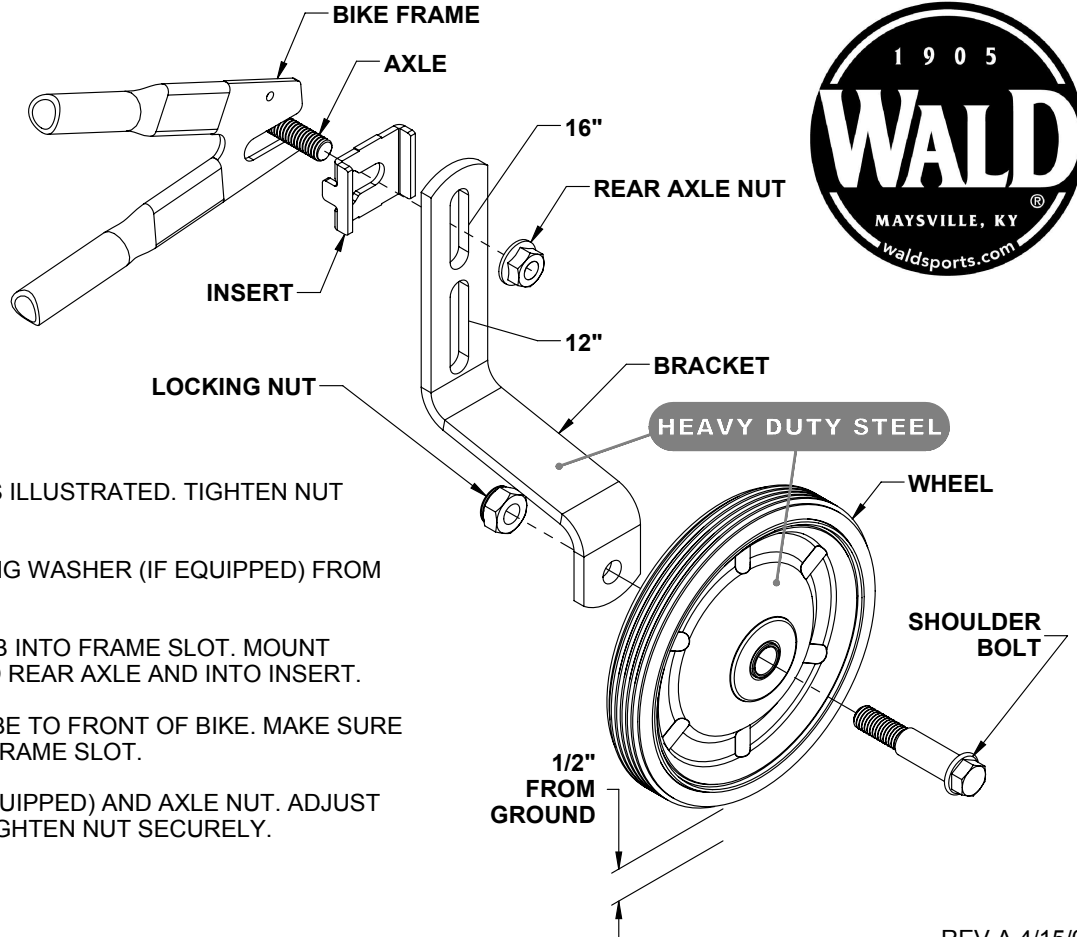

ASSEMBLY INSTRUCTIONS :

1. ASSEMBLE WHEEL TO BRACKET AS ILLUSTRATED. TIGHTEN NUT SECURELY.
2. REMOVE REAR AXLE NUT & LOCKING WASHER (IF EQUIPPED) FROM BIKE, ONE SIDE ONLY.
3. CENTER INSERT ON AXLE WITH TAB INTO FRAME SLOT. MOUNT WHEEL-BRACKET ASSEMBLY ONTO REAR AXLE AND INTO INSERT.

NOTE : IF POSSIBLE, TAB SHOULD BE TO FRONT OF BIKE. MAKE SURE THE TAB CATCHES IN THE FRAME SLOT.

4. REPLACE LOCKING WASHER (IF EQUIPPED) AND AXLE NUT. ADJUST WHEEL 1/2" FROM GROUND AND TIGHTEN NUT SECURELY.
5. REPEAT FOR OTHER SIDE.